

Watkins-Johnson WJ-8718A MFP “Convertible”

Raymond Boute ON4DBV — raymond.boute@pandora.be — 2017/04

These notes pertain to a WJ-8718A that has been converted in a reversible way from the *basic* variant into the *microprocessor front panel* (MFP) variant. Together with the schematics in the manuals referenced below, this information allows reconfiguring the receiver in a short time.

A. Basic variant

We assume the basic variant using modules MFP-A4 and MFP-A3 instead of A6A1 and A6A2.

a. Configuration — basic variant (Front panel S/N: 3292)

Label	Type	Function	Descr.	Parts	Schem.
A1	76240	Power Distribution	3-52	5-13	6-39
A2	791616	RF Filter	3-3	5-14	6-1
PRE-A1	796012	Preselector	(suppl.)		
A3	791592	Input Converter	3-4	5-15	6-3
A4	791569	(Rev. A) IF Motherboard	3-5	5-21	6-39
A4A1	791594	10.7 MHz Filter Switch	3-5	5-22	6-5
A4A2	791430	10.7 MHz 455 kHz Converter	3-6	5-26	6-7
A4A3	791595	455 kHz Filter Switch	3-6	5-27	6-9
A4A4	791596	USB Filter Switch	3-7	5-30	6-11
A4A5	791597	LSB, ISB Filter Switch	3-8	5-32	6-13
A4A6	78112	AGC Amplifier	3-9	5-35	6-15
A4A7	72488	455 kHz Amplif., AM Detect.	3-8	5-38	6-17
A4A8	791598	ISB Detector/Audio	3-15	5-42	6-19
A4A9	791599	FM, CW, SSB Detector	3-12	5-46	6-21
A4A10	7459	Audio Amplifier	3-13	5-48	6-23
A5	791570	(Rev. B) Synthesizer Motherboard	3-17	5-51	6-39
A5A1	791630	1st and 3rd LO Synthesizer/Timebase	3-42	5-54	6-25
A5A1A1	791629	1st LO VCO Assembly	3-34	5-55	6-27
A5A1A2	791600	1st and 3rd LO Synthesizer	3-24	5-60	6-29
A5A2	791601	2nd LO Synthesizer	3-31	5-66	6-31
A5A3	791576	BFO Synthesizer	3-27	5-74	6-33
A6	791580	(Rev. B) I/O Motherboard	3-42	5-76	6-39
MFP-A3	794308	IF Interface	3-34*	5-27*	6-11*
MFP-A4	794275-1	Synthesizer Interface and Memory	3-26*	5-30*	6-13*
488M-A3	796075	IEEE 488 Interface	3-42*	5-32*	6-15*
—	796002	Preselect. Decode	(suppl.)		
A7	791874-1	Manual Tuning Module	3-47	5-81	6-39
A7A1	791589	(Rev. A) Tuning Resolution	3-48	5-82	6-39
A8	791578	(Rev. B) Frequency Display	3-49	5-83	6-37
A9	791827	(Rev. A) BFO Switch	3-50	5-85	6-39
A10	791684	Front Panel Control	3-50	5-86	6-39
A10A1	791583	(Rev. B) Upper Panel Control	3-51	5-87	6-39
A10A2	796054	(Rev. B) Lower Panel Control [791826]	[3-51]	[5-88]	[6-39]

Hyphenated numbers: pages in the *Instruction Manual for WJ-8718*, Rev. IV, Feb. 1979

Asterisks (*): page numbers in the *Instruction Supplement for WJ-8718A/MFP*, 3/84

b. Location of modules — basic variant (top view unless indicated otherwise)

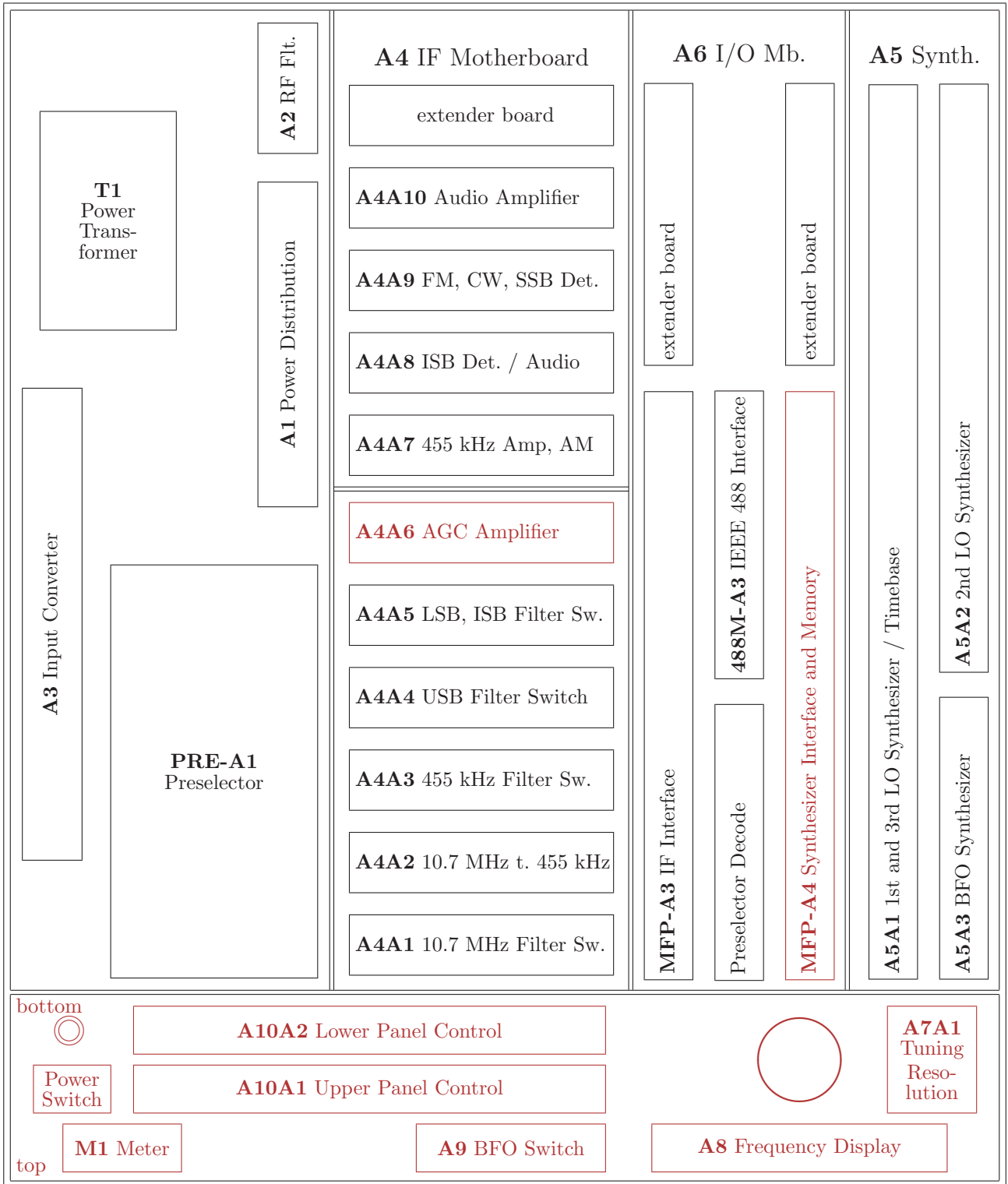

c. Front panel connection — basic variant The front panel is connected to the MFP-A3 board as shown by the “exploded view” in Figure 1. The 40-wire flat cable on the left goes to the radio button switches. The other three flat cables go to the optical rotary encoder, the BFO thumbwheel switches and the frequency display, as indicated on the labels.

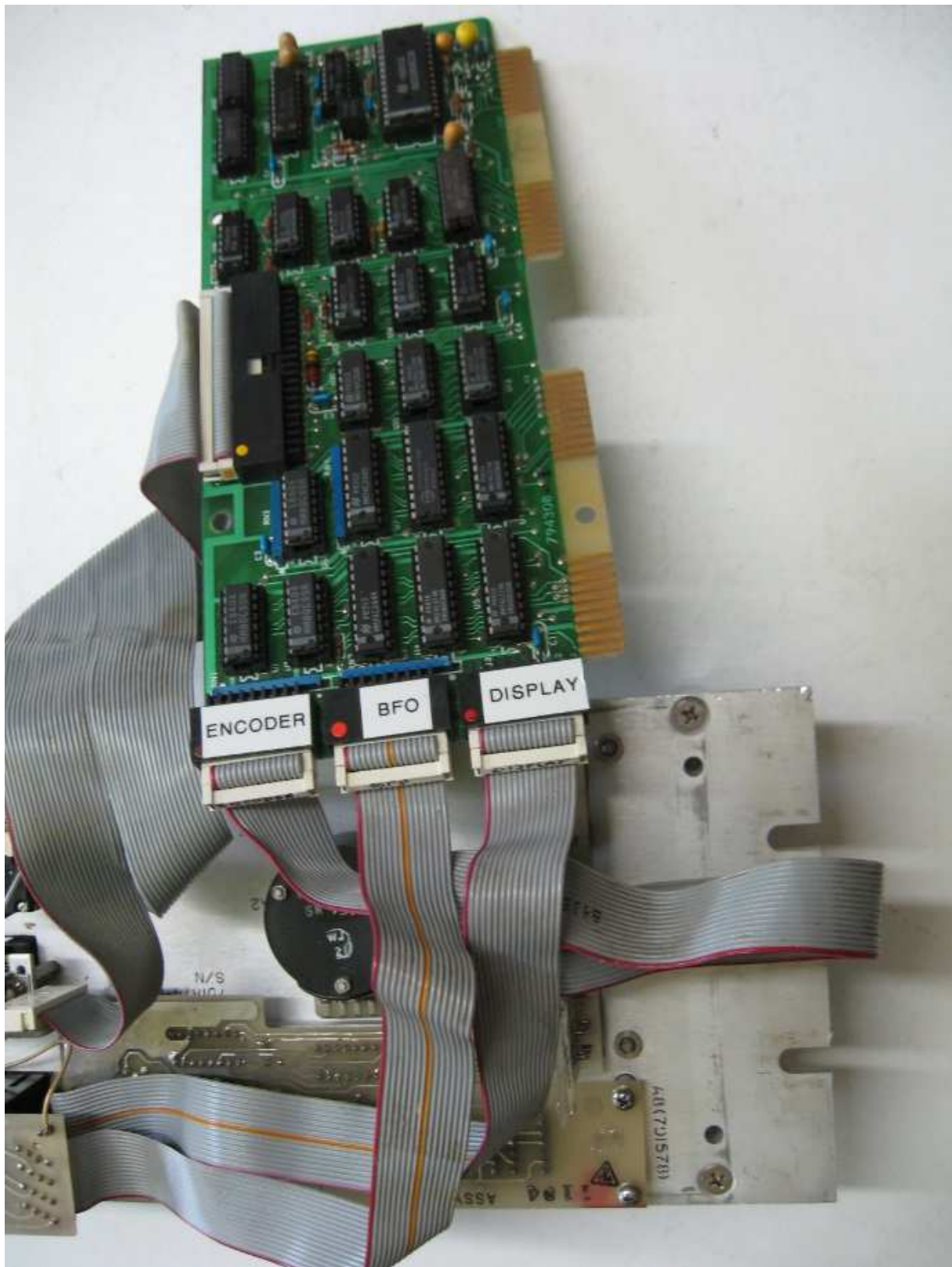

Figure 1: Front panel interconnections for the basic variant using MFP-A3

B. MFP variant

a. Configuration (Front panel S/N: 4040)

Label	Type	Function	Descr.	Parts	Schem.
A1	76240	Power Distribution	3-52	5-13	6-39
A2	791616	RF Filter	3-3	5-14	6-1
PRE-A1	796012	Preselector	(suppl.)		
A3	791592	Input Converter	3-4	5-15	6-3
A4	791569	(Rev. A) IF Motherboard	3-5	5-21	6-39
A4A1	791594	10.7 MHz Filter Switch	3-5	5-22	6-5
A4A2	791430	10.7 MHz 455 kHz Converter	3-6	5-26	6-7
A4A3	791595	455 kHz Filter Switch	3-6	5-27	6-9
A4A4	791596	USB Filter Switch	3-7	5-30	6-11
A4A5	791597	LSB, ISB Filter Switch	3-8	5-32	6-13
A4A6	796175-1	AGC Amplifier		5-11*	6-3*
A4A7	72488	455 kHz Amplif., AM Detect.	3-8	5-38	6-17
A4A8	791598	ISB Detector/Audio	3-15	5-42	6-19
A4A9	791599	FM, CW, SSB Detector	3-12	5-46	6-21
A4A10	7459	Audio Amplifier	3-13	5-48	6-23
A5	791570	(Rev. B) Synthesizer Motherboard	3-17	5-51	6-39
A5A1	791630	1st and 3rd LO Synthesizer/Timebase	3-42	5-54	6-25
A5A1A1	791629	1st LO VCO Assembly	3-34	5-55	6-27
A5A1A2	791600	1st and 3rd LO Synthesizer	3-24	5-60	6-29
A5A2	791601	2nd LO Synthesizer	3-31	5-66	6-31
A5A3	791576	BFO Synthesizer	3-27	5-74	6-33
A6	791580	(Rev. B) I/O Motherboard	3-42	5-76	6-39
MFP-A3	794308	IF Interface	3-34*	5-27*	6-11*
MFP-A4	794275-1	Synthesizer Interface and Memory	3-26*	5-30*	6-13*
488M-A3	796075	IEEE 488 Interface	3-42*	5-32*	6-15*
—	796002	Preselect. Decode	(suppl.)		
MFP		MFP Option Main Assembly			6-19*
MFP-A1	784310-1	Front Panel Interconnect	3-1*	5-15*	6-5*
MFP-A1A1	796056-1	Front Panel Encoder	3-7*	5-17*	6-7*
MFP-A1A2	794309-1	Front Panel Switch Board (& display)	3-5*	5-21*	6-9*
MFP-A2	791202-5	Encoder Assembly (optical)	3-1*	5-24*	

Hyphenated numbers: pages in the *Instruction Manual for WJ-8718*, Rev. IV, Feb. 1979

Asterisks (*): page numbers in the *Instruction Supplement for WJ-8718A/MFP*, 3/84

b. Location of modules — MFP variant (top view unless indicated otherwise)

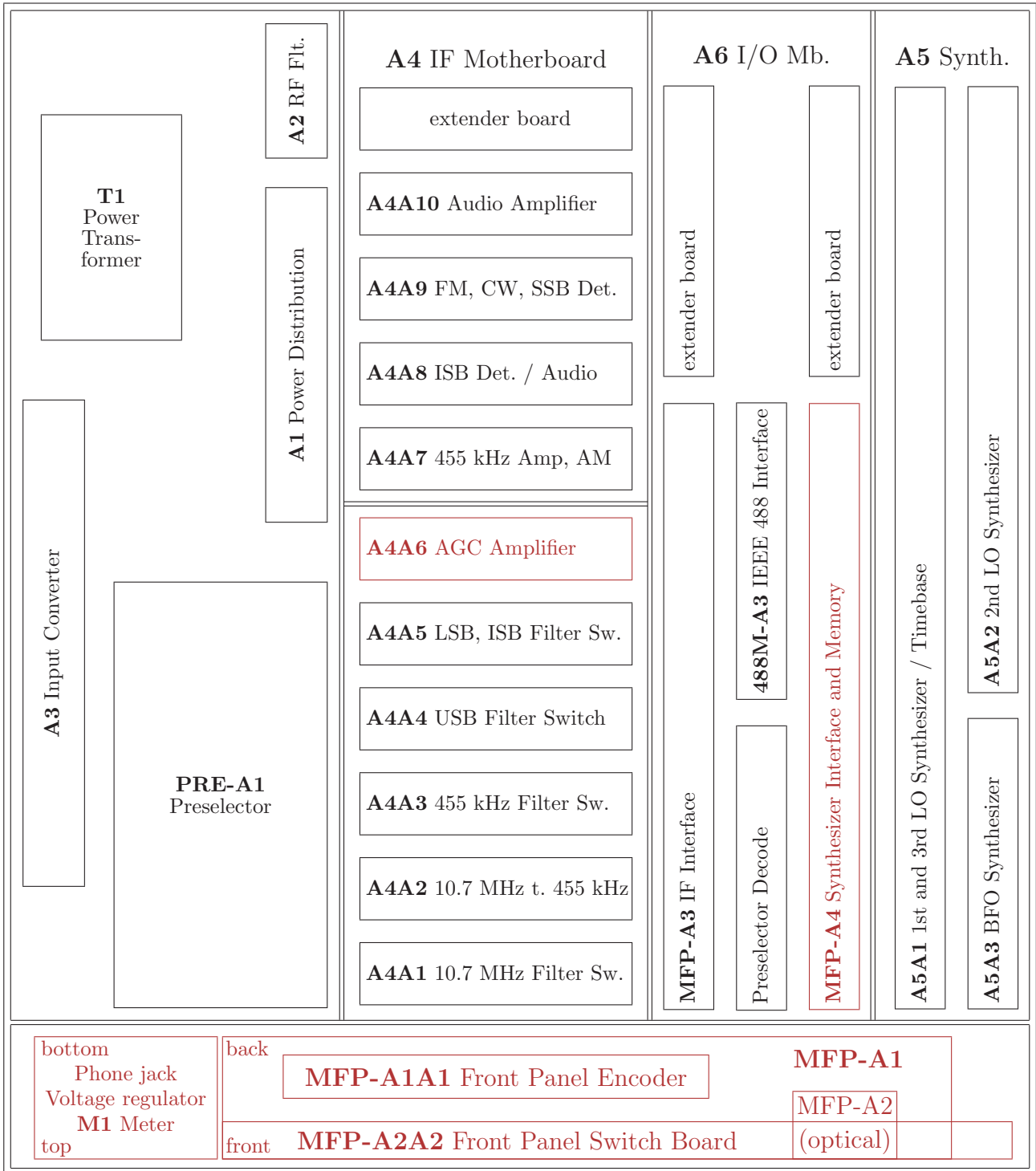

c. Front panel connections — MFP variant (Front panel S/N: 4040)

The connections to the front panel consist of various cables shown in Figure 2, which is part of Figure 6-9 on page 6-19 of the *Instruction Supplement for WJ-8718A/MFP*.

If some of the original cables are not available, one can proceed as follows.

For the power interconnections (P-43 and P-44 in Figure 2), connect wires to C11 and C12 and use fastons in heat-shrink tubing. The result is visible in Figure 3 (the brown and red wires at the top).

For the cable MFP-W1, one can use any 13-wire (flat) cable with separate female connectors matching the pins on the connectors. In Figure 4, the leftmost part shows the connections to

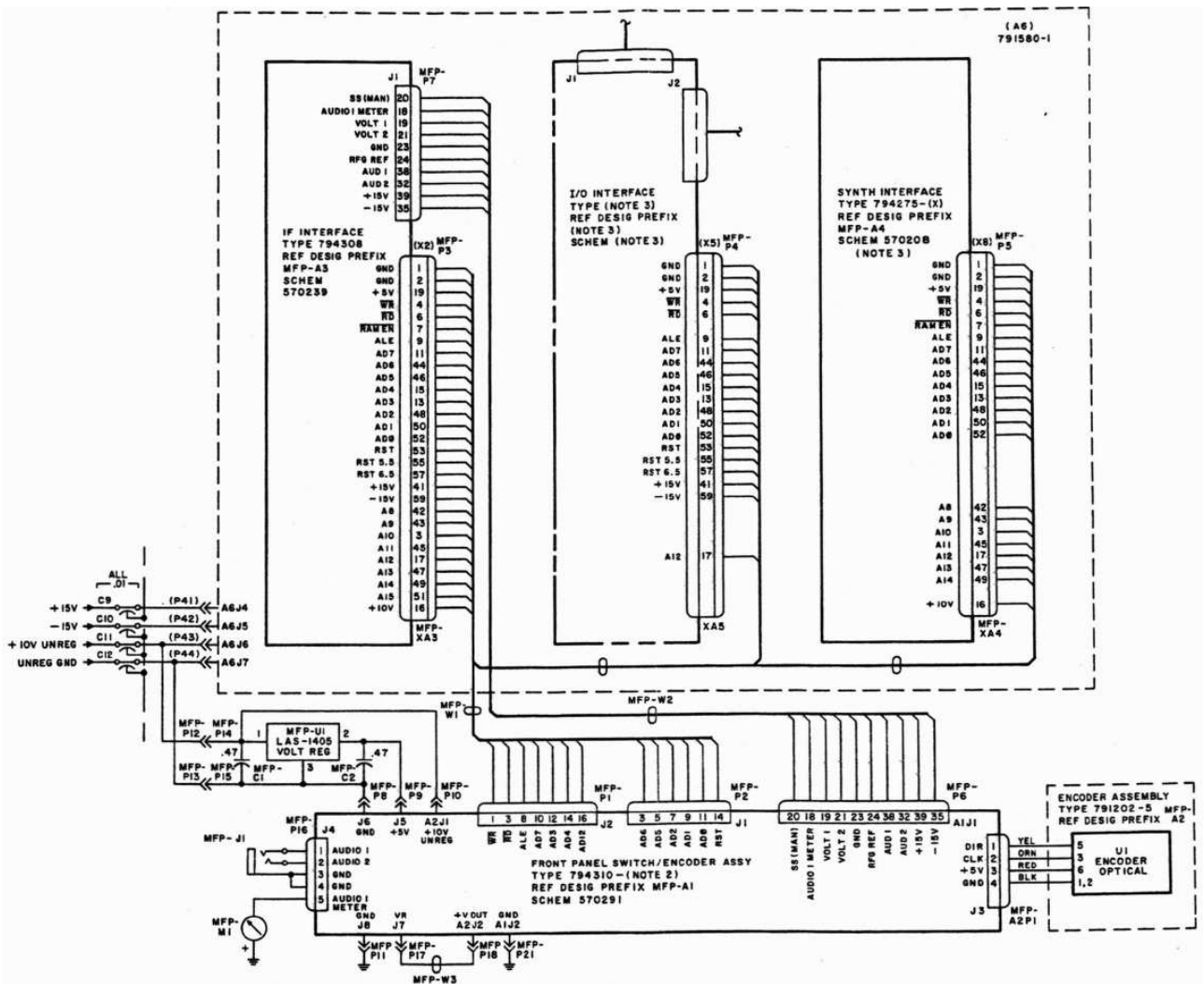

Figure 2: Front panel connections for the MFP



Figure 3: Power connections to the front panel

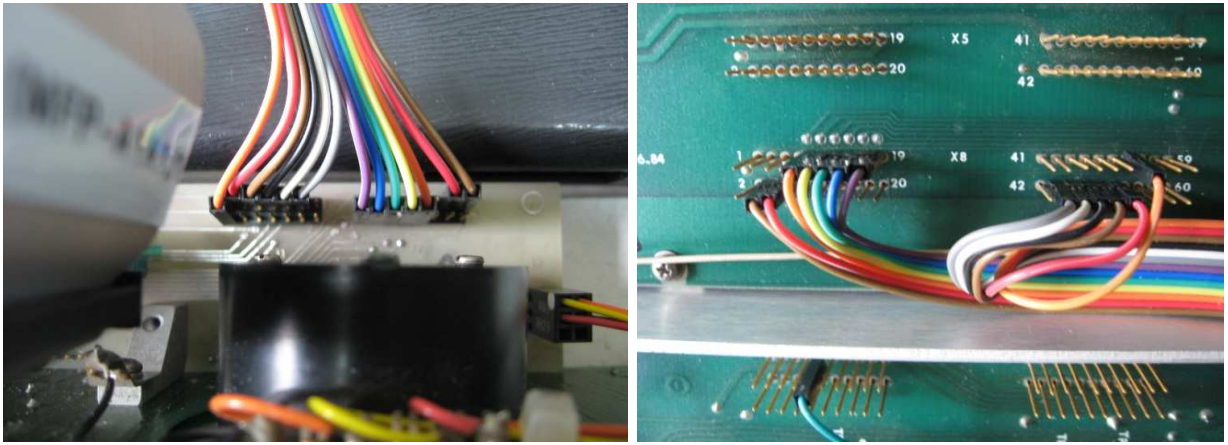

Figure 4: Connections using a substitute for cable MFP-W1

MFP-A1J1 and MFP-A2J2, whereas the rightmost part shows the corresponding connections to the motherboard A6. On A6, the connector X8 was chosen instead of X5, which makes no difference for the 13 pins involved. The reason for the switch is that these pins must be cut a bit shorter, lest the cable connectors prevent installing the bottom cover. Leaving X5 intact allows using it when a genuine MFP-W1 becomes available. The shorter pins on X8 have the fringe benefit of indicating the places where wires must be connected.

For the cable MFP-W2, one can use a 30 cm standard 40-wire flat cable with proper connectors, easily found fully assembled on eBay. The genuine MFP-W2 is a few cm shorter, which leaves less room for installation. One end is connected to MFP-[A1]A1J1 (blurred on the leftmost photograph in In Figure 4. The other end (MFP-P7) is connected to MFP-[A6]A3J1, as shown in Figure 5.

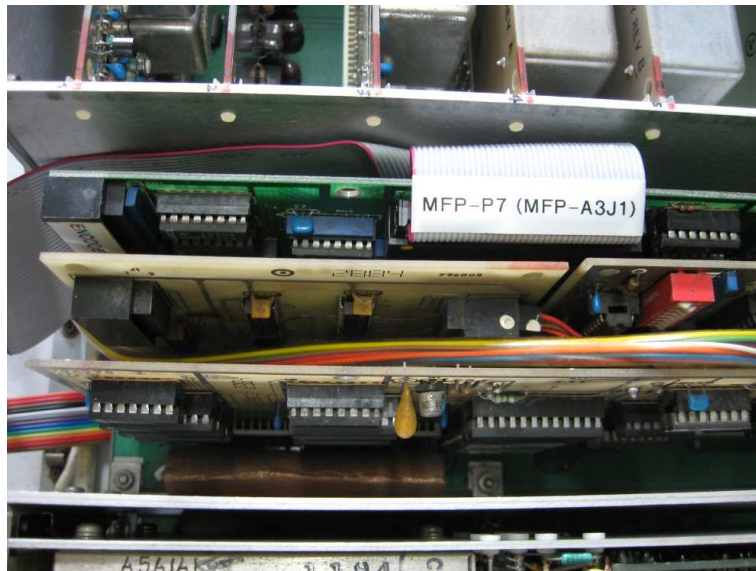

Figure 5: Connecting MFP-P7 of cable MFP-W2 to MFP-[A6]A3J1

C. Additional remarks

About the reconfiguration Apart from connecting the front panel as described in the preceding sections, reconfiguring between the basic and the MFP variant also requires changing A4A6 (AGC amplifier) and the firmware on MFP-A4.

In 2017, Paolo Viappiani published two articles:

“The Watkins-Johnson 8716/8718-Series Receivers”, *Electric Radio #335*, pp. 36-47, April 2017,

“The Watkins-Johnson 8716/8718-Series Receivers, Part 2”, *Electric Radio #337*, pp. 18-28, June 2017,

which are a very useful source of information for any WJ-8716/8718 experimenter or user.

In the rightmost column on page 38 of the first paper, Paolo notes that, in some models of the “basic” or “plain” (i.e., non-MFP) version, boards were replaced as follows.

Original	Replacement
A6A1 (791575-2) Manual Tuning Up/Down Counter	MFP-A4 (794275) Synthesizer Interface/Memory
A6A2 (791828) Front Panel Interconnect	MFP-A3 (794308) IF Interface

In fact, MFP-A4 is a microprocessor board that, depending on the firmware, can serve both the plain and the MFP version. Similarly, MFP-A3 can serve both versions.

As shown in Figure 1, this board combines all four front panel connections of A6A1 and A6A2 for the basic configuration.

In the MFP configuration, the connectors marked ENCODER, BFO and DISPLAY are not used, and only MFP-[A6]A3J1 is connected (via MFP-W2) to the front panel. All display and control functions of the front panel are performed by the microprocessor module MFP-A4 via the bus MFP-W1.

About the WJ identifier scheme for assemblies, subassemblies and connectors In the identifiers for subassemblies or connectors, the identifier of the assembly at the higher level is often omitted in the schematics and in the tags on the cables. The scheme for these abbreviations is quite systematic, yet can lead to ambiguity.

This is important for correctly interpreting Figure 2. For instance, the identifier MFP-A1J1 as it appears in the tag “MFP-P2 (MFP-A1J1)” on the original cable MFP-W1 refers to J1 on the MFP-A1 motherboard (the narrow, long horizontal board fixed with solid aluminum brackets to the front panel). On cable MFP-W2, the same identifier MFP-A1J1 appears in the tag “MFP-P6 (MFP-A1J1)” but here it refers to J1 on the MFP-A1A1 plugin board.

Further illustrations are found in Figure 6-2 on page 6-5 of the *Instruction Supplement for WJ-8718A/MFP*. The dashed box represents MFP-A1, and the long rectangles represent MFP-A1A1 and MFP-A1A2. The two different pin connectors mentioned appear on MFP-A1 and MFP-A1A1 under the same name J1.